

# Perfect W Technical Picture

## Perfect W Single Door

This 5mm space is used to adjust the track level,  
The installation size is subject to the door fan  
minus ruler rule.

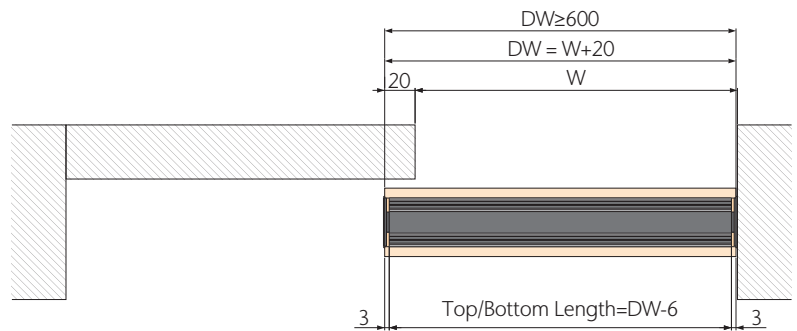
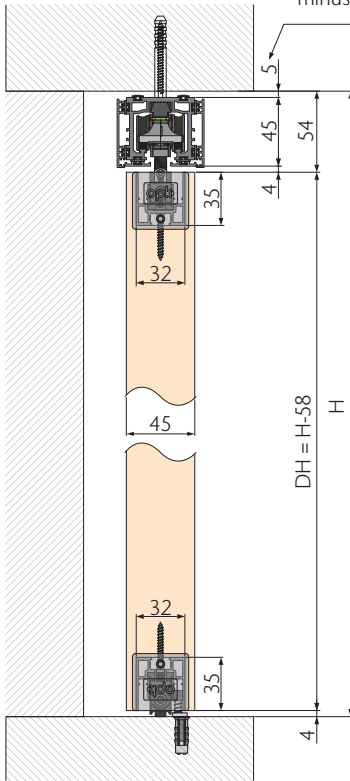

## Perfect W Two Doors

This 5mm space is used to adjust the track level,  
The installation size is subject to the door fan  
minus ruler rule.

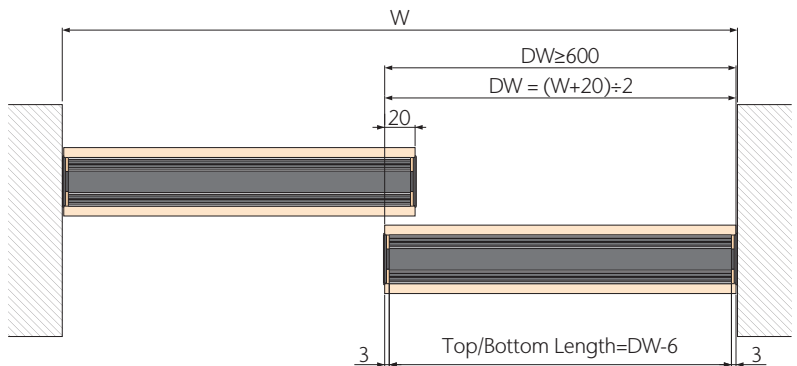
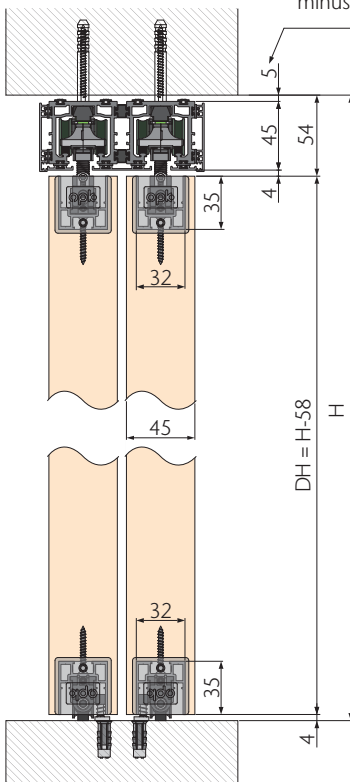



Perfect W Stacking 4 Doors

This 5mm space is used to adjust the track level,  
The installation size is subject to the door fan  
minus ruler rule.

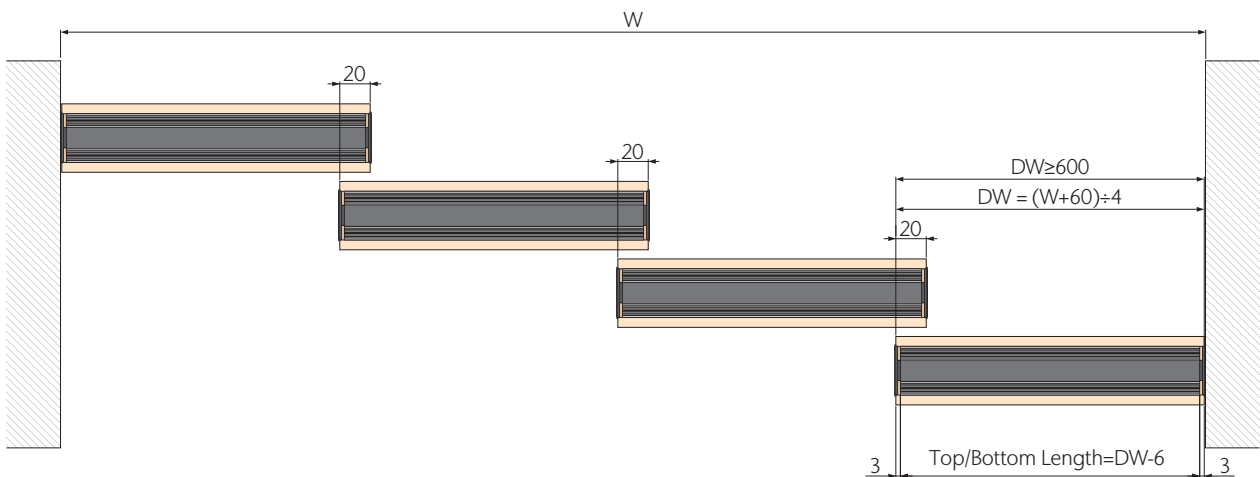
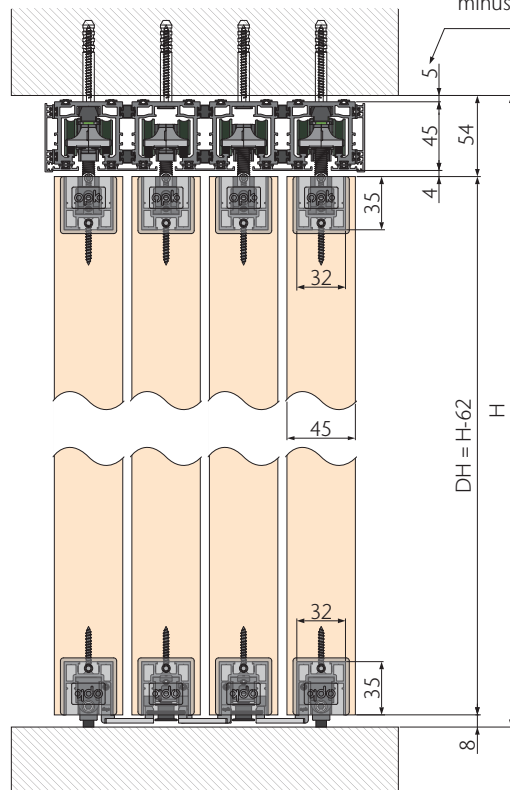

Perfect W Stacking 5 Doors

This 5mm space is used to adjust the track level,  
The installation size is subject to the door fan  
minus ruler rule.

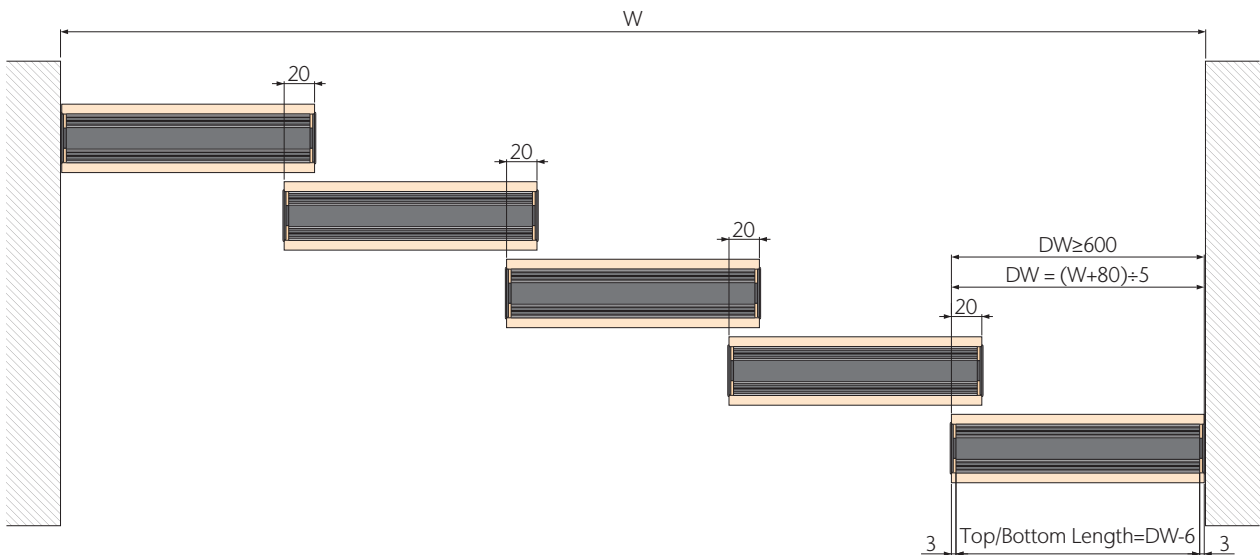
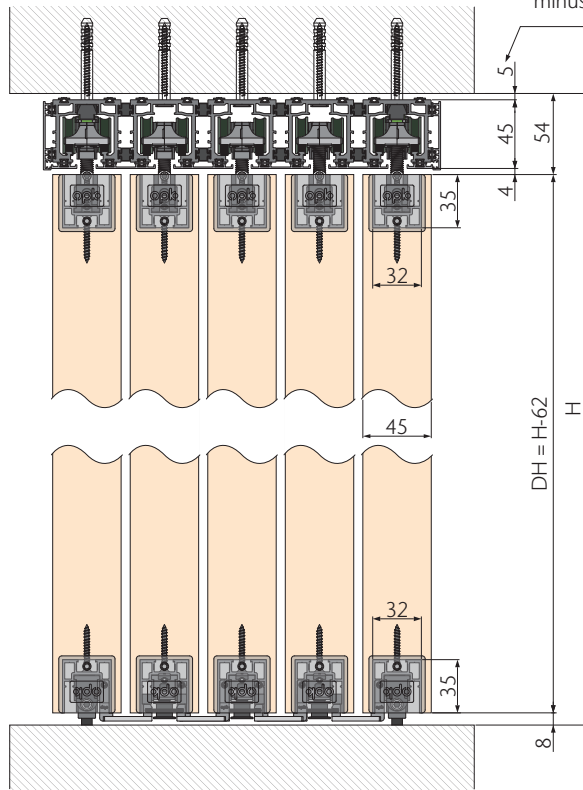

Perfect W Stacking 6 Doors

This 5mm space is used to adjust the track level,  
The installation size is subject to the door fan  
minus ruler rule.

